

Time: 4 Hours

Total Marks: 80

- N.B.** 1) Question No 1 is compulsory.
 2) Solve any **three** questions from remaining questions.
 3) Assume suitable data if required but justify same.
 4) Use of IS 800 and steel table is permitted in the examination hall.
 5) Figures to the right indicate full marks.

- Q.1** (a) A truss as shown in fig. is used for an industry situated in Mumbai. The truss is covered with AC sheet 171 N/m^2 . Calculate panel point dead load, live load and wind load. Design the members LoL1, LoU1 and U1L1 and draw the design details Assume $K_1 = 1$, $K_2 = 0.99$, $(C_{pe} - C_{pi}) = -0.9$, $k_3 = 1$, self-weight of purlin is 200 N/m and spacing of truss is 3 m . **26**

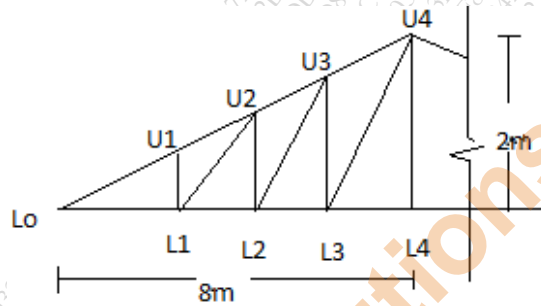

- (b) Design the channel section purlin for the above truss. **6**

OR

- Q.1** (a) The flooring system of an industrial shed is planned as shown in fig Design Beam SB1 And MB1 And a beam to beam connection between them with top flange of beam at same level. Use ISLB or ISMB section to design beam assuming beam to be laterally supported throughout for the following data. **26**
 Thickness of slab - 150 mm
 Thickness of wall 230 mm , height of wall is 1.5 m on all beams.
 Live load is 2 kN/m^2 , floor finish load is 0.75 kN/m^2
 Unit weight of concrete and wall 25 kN/m^3 and 20 kN/m^3 respectively.

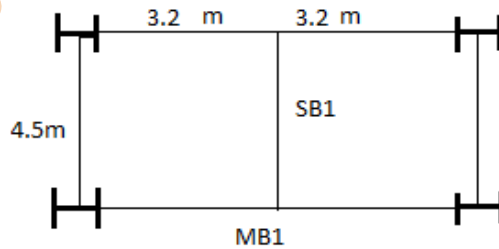

- (b) Design the bolted connection between MB1 and column flange using 4.6 grade bolts. Sketch the connection details. **6**

- Q.2 (a) A column ISHB 350 at 661.2 N/m carries compressive factored load is 1660kN. Design suitable bolted gusset base. The base rests on M15 grade concrete pedestal. Use 24mm diameter bolts of grade 4.6 for making the connection .The SBC of soil is 150kn/m². 12
- Sketch plan, elevation and side view of the gusseted base you designed.
- (b) Write step by step procedure to design slab base. 4
- Q.3 (a) Design built up column using batten system 9m long to carry a factored axial load of 1300 kN column is fixed at both ends .Assume that two channels are kept back to back. Use 4.6 grade bolts for the connection. Draw the neat sketch to show details of the design. 14
- (b) Estimate the design load for the column in Q3(a) if lacing system is used. 2
- Q.4 Design a welded plate girder 18 m in span and laterally supported throughout. It has to support UDL of 85 kN/m throughout the span exclusive of self weight. Assume the steel is of grade Fe 410 .Also design the connections between web and flange plate. Design central section of the plate girder for bending and shear .Also design two step curtailment for flange plates. Sketch the plan,elevation and section of the plate girder. 16
- Q.5 (a) For the connection as shown in fig if the load is 100 kN inclined at 30⁰ to the vertical in clockwise direction Check whether the fillet weld is safe. Assume that field weld is used. 8

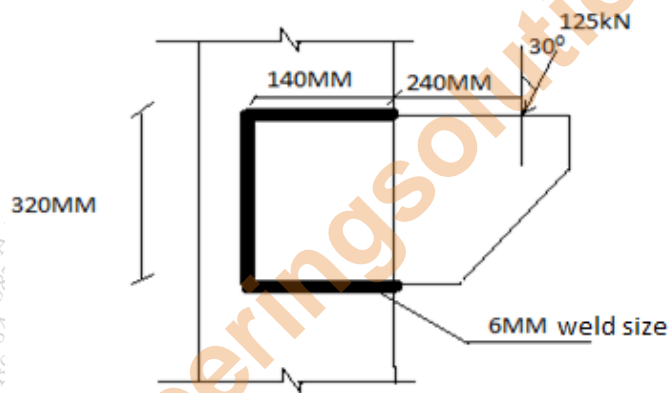

- (b) A simply supported steel joist of 5m span has to support a load of 60kN/m(inclusive of self-weight) .The beam compression flange is not restrained against buckling. Design an appropriate section using steel of grade Fe 410 8
